

Thermal Dispersion & Paddle Type Flow Switch

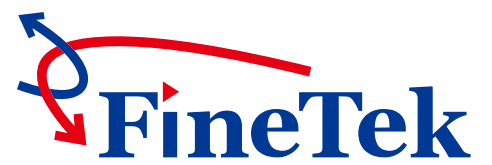

www.fine-tek.com



PRODUCT INTRODUCTION

OPERATING PRINCIPLE

Thermal dispersion flow switches measure the velocity of a liquid inside a pipe or channel. The switch's probe contains two key components – a heating sensor and temperature sensor. The heating sensor is positioned closest to the flowing liquid and provides a consistent heat. The temperature sensor measures the temperature emitted from the heating sensor.

When liquid is flowing, there is a temperature difference between the two sensors. The temperature difference has an inverse relationship with the flow velocity (fast flowing liquids will result in greater heat differences and vice versa). Since the device contains no moving parts, has no wear and tear and maintains a long lifespan.

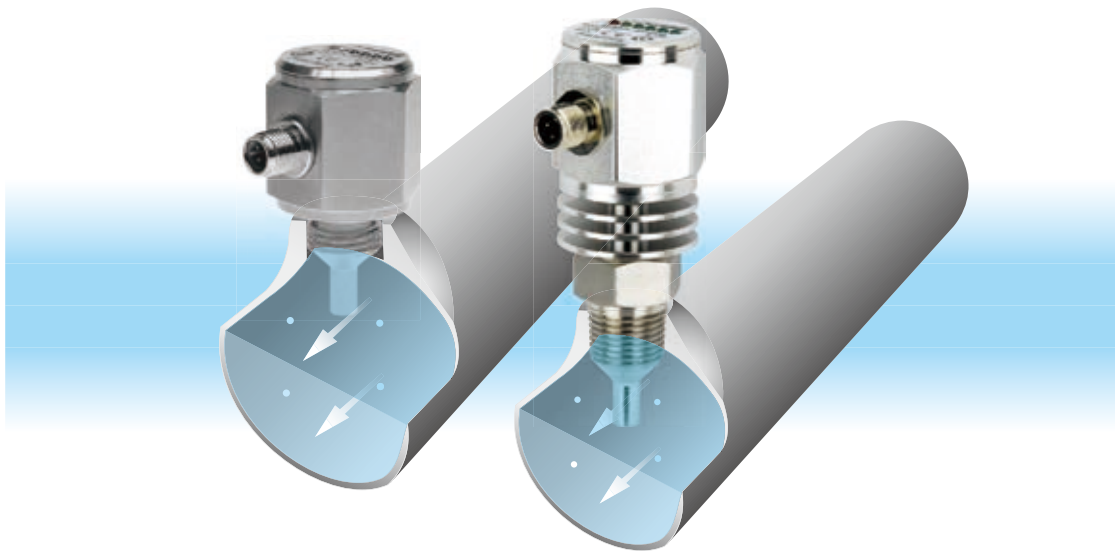

FEATURES

- High sensitivity and accuracy.
- Suitable for corrosive and hazardous conditions.
- Able to be calibrated for liquids with different densities and impurities.
- Suitable for complex locations with easy installation.
- Customized probe lengths available.
- Three different output signals options.

APPLICATION

Petrochemicals, Hydroelectric plants, Shipyard, HVAC Systems, Steel Industry Food and Beverage, Pharmaceutical, Optics and Semiconductor Industry, Cooling pipes flow control
Any pipes carrying liquid where flow measurement is needed.

PRODUCT SPECIFICATIONS

Drawings			
Model	SP200-□-□-□-□-□ Compact model	SP201-□-□-□-□-□ Extension model	SP202-□-□-□-□-□ High Temp. model
Measuring range	Water: 1~150 cm/s Oil: 3~300 cm/s	Water: 1~150 cm/s Oil: 3~300 cm/s	Water: 1~150 cm/s Oil: 3~300 cm/s
Ambient temp.	-20 ~ 80°C	-20 ~ 80°C	-20 ~ 80°C
Operating temp.	-20 ~ 80°C	-20 ~ 80°C	-20 ~ 120°C
Alarm output	Open Collector : NPN / PNP(<400mA) Relay : 1A/30Vdc, 0.3A/125Vac (NO or NC)		
Operating pressure	100 bar (max.)	100 bar (max.)	100 bar (max.)
Led indication	Flow velocity below set point- Red LED on, Open Flow velocity equals set point- Yellow LED on, Close Flow velocity above set point- 4 Green LED to indicate flow speed, Close		
Housing	SUS304 / 316 / 316L		
Wetted part	SUS304 / 316 / 316L		
Protection level	IP67		
Warm-up time	Approx. 10 Sec	Approx. 15 Sec	Approx. 15 Sec
Connection thread	G1/2, G1/4, NPT1/2	G1/2, NPT1/2	G1/2, G1/4, NPT1/2
Operating voltage	19 ~ 30Vdc		
Power consumption	50mA (max.)		
Wiring	3-wire NPN/PNP Power-brown Grounding-blue Output-black		
Accessory	Gasket, 2m Cable		

PRODUCT SPECIFICATIONS

<p>Drawings</p>	
<p>Model</p>	<p>SP220-□-□□-□-□ Economy model</p>
<p>Measuring range</p>	<p>Water: 1~150 cm/s Oil: 3~300 cm/s</p>
<p>Ambient temp.</p>	<p>-20 ~ 80°C</p>
<p>Operating temp.</p>	<p>-20 ~ 80°C</p>
<p>Alarm output</p>	<p>Open Collector : NPN / PNP (<400mA) Relay : 1A/30Vdc, 0.3A/125Vac (NO or NC)</p>
<p>Operating pressure</p>	<p>100 bar (max.)</p>
<p>Led indication</p>	<p>Flow velocity below set point- Red LED on, Open Flow velocity equals set point- Yellow LED on, Close Flow velocity above set point- 4 Green LED to indicate flow speed, Close</p>
<p>Housing</p>	<p>PC</p>
<p>Wetted part</p>	<p>SUS304 / 316 / 316L</p>
<p>Protection level</p>	<p>IP65</p>
<p>Warm-up time</p>	<p>Approx. 15 Sec</p>
<p>Connection thread</p>	<p>G1/2, NPT1/2</p>
<p>Operating voltage</p>	<p>19 ~ 30Vdc</p>
<p>Power consumption</p>	<p>50mA (max.)</p>
<p>Wiring</p>	<p>3-wire NPN/PNP Power-brown Grounding-blue Output-black</p>
<p>Accessory</p>	<p>Gasket, 2m Cable</p>
<p>Footnote</p>	<p>Sensitivity and Alarm setting not available.</p>

PRODUCT SPECIFICATION

Drawings			
		Cert. Number GYJ12.1521x	Cert. Number GYJ12.1521x
Model	SP210 Stainless Steel model	SP170-(1/2) Explosion Proof model	SP171-(1/2) Explosion-proof extension model
Measuring range	Water: 1~150 cm/s Oil: 3~300 cm/s		
Ambient temp.	-20 ~ 80°C		
Operating temp.	-20 ~ 80°C		
Alarm output	Relay: 5A/250Vac	Relay: 3A/250Vac	
Operating pressure	100 bar (max.)		
Led indication	Flow velocity below set point- Red LED on, Open Flow velocity equals set point- Yellow LED on, Close Flow velocity above set point- 4 Green LED to indicate flow speed, Close		
Housing	SUS304		
Wetted part	SUS304 / 316 / 316L		
Protection level	IP67		
Warm-up time	Approx. 15 Sec		
Connection thread	G1/2, NPT1/2		
Operating voltage	19 ~ 30Vdc		
Power consumption	60mA (max.)		
Wiring	5-wire Relay Output Power- red Grounding- black COM- white NC- yellow NO- blue		
Accessory	Gasket, 2m Cable	_____	_____

INSTALLATION

INSTALLATION

1. Use the water-proof gasket provided
2. The distance "a" should be 4 times larger than the switches' screw diameter. (Fig. 1)
3. The pipe is bubble free for proper functioning. (Fig. 2)
4. For not-completely-filled pipes, install from the bottom. The liquid level needs to be higher than the probe height. (Fig. 3)
4. Screw tightly to avoid. Can be installed from various angles. For best sensitivity and response speed, please install using in the demonstrated in Fig. 4
5. Installing a filter upstream can decrease liquid impurities which can reduce wear and tear on the switch.

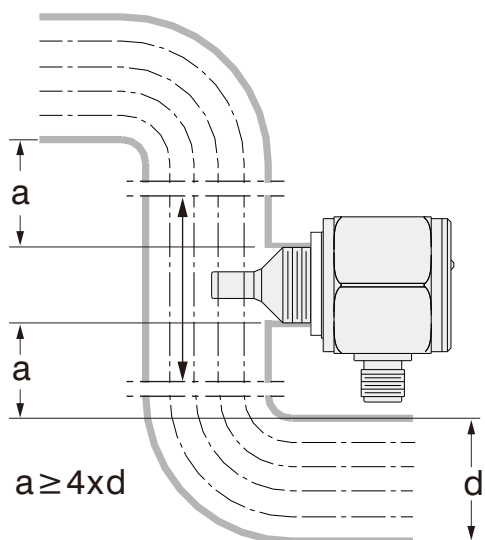

Fig. 1

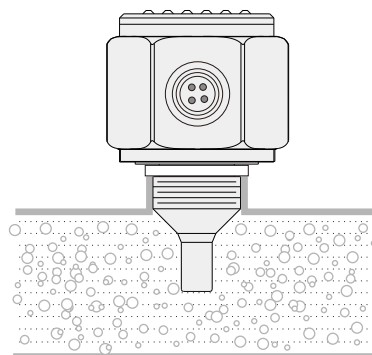

Fig. 2

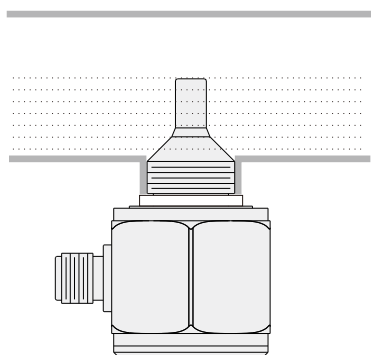

Fig. 3

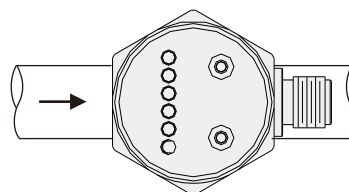

Fig. 4

CWIRING AND CONNECTIONS

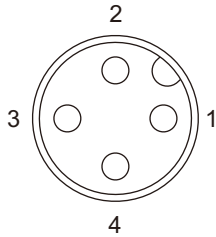

Fig. 5
Wire terminal diagram
(NPN, PNP and 1A relay output type)

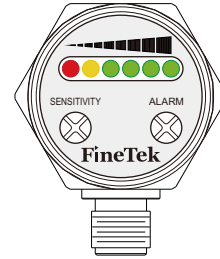

Fig. 6

WIRING

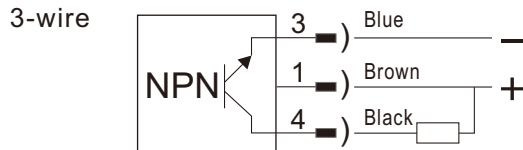

Fig. 7, NPN output type wiring

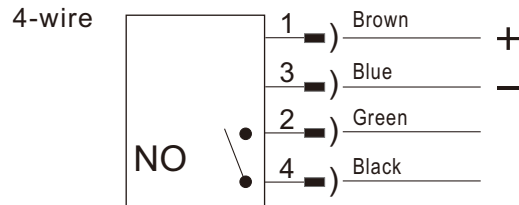

Fig. 10, Relay output type wiring (NO)

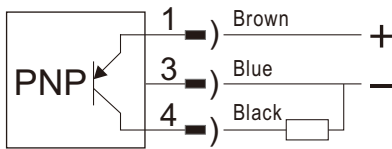

Fig. 8, PNP output type wiring

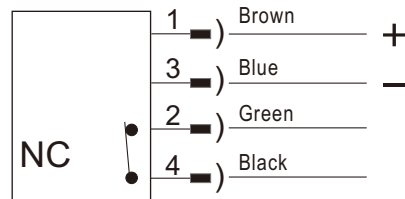

Fig. 11, Relay output type wiring (NC)

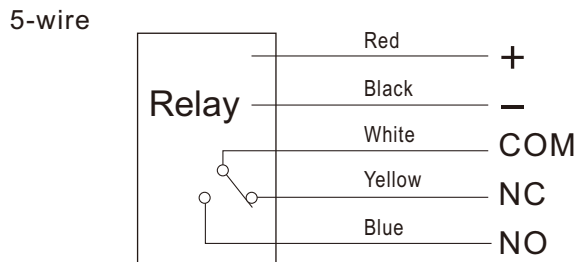
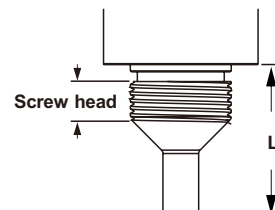

Fig. 9, Relay output type wiring

SCREW TABLE

Screw	Standard			
	PF,BSP		PT,NPT	
	Screw head	L	Screw head	L
1/4"	8.5mm	25mm	10mm	25mm
1/2"	10.5mm	31mm	19mm	40mm
1"	16mm	36mm	20mm	40mm

Screw	Extension			
	PF,BSP		PT,NPT	
	Screw head		Screw head	
1/2"	11.5mm	16mm	16mm	20mm
1"	16mm		20mm	



HOW TO ORDER

SP2 - - - - - ()

Model Description

- 0: Compact model
- 1: Stainless Steel model $\phi 70 \times 78$
(for SPDT 5A/250Vac)
- 2: Economy model (Plastic Housing)

Probe Type

- 0: Standard model
- 1: Probe Extension model
- 2: 120°C High Temperature model
(Except SP220)

Material

- 0: SUS304 L: SUS316L S: Other
- 6: SUS316

Connection

Size	Specification
A: 3/8" (10A)	Q: PT
B: 1/2" (15A)	T: BSP
C: 3/4" (20A)	R: PF
D: 1" (25A)	U: NPT
2: 1/4"	V: GAS
S: Other	S: Other

*Standard connection: 1/2"PF, 1/2"NPT, 1/2"PT

Output

- N: NPN (current limit: 400mA)
- P: PNP (current limit: 400mA)
- A: Relay 1A/30Vdc (NO)
- B: Relay 1A/30Vdc (NC)
- C: Relay 5A/250Vac (SPDT) (for SP210/ SP211/ SP212)

Cable Wire Length(unit: m)

- 2: 2m 5: 5m

Length L (Unit: mm)

- ※ Length tolerance: $\pm 5\text{mm}$
- ※ Dimensions are subject to change
- ※ Customized lengths available on request * Max.200mm

HOW TO ORDER

SP170- - - - ()

Model Description

- 70 ---Explosion Proof Type
- 71 ---Explosion-proof extension(Max:L=200mm)

Material

- 1: SUS304
- 2: SUS316L
- 6: SUS316

Continue

Size	Specification
B: 1/2" (15A) D: 1" (25A) S: Other	Q: PT T: BSP R: PF V: GAS U: NPT S: Other

Output

- C: SPDT 3A/250Vac

Length L (Unit: mm)

- ※ Length tolerance: ± 5mm
- ※ Dimensions are subject to change
- ※ Customized lengths available on request * Max.200mm

PADDLE TYPE FLOW SWITCH

PRINCIPLE

Flow Switch can detect liquid movement in pipes. When the liquid is static or nonexistent, the spring is fully extended pulling the magnet downward and opening the switch. As flow occurs and the paddle is thrust forward 20°C~30°C (or more) the paddle will push the magnet upward and actuate the switch (closing the circuit). The length of paddle can be adjusted to the pipe's diameter.

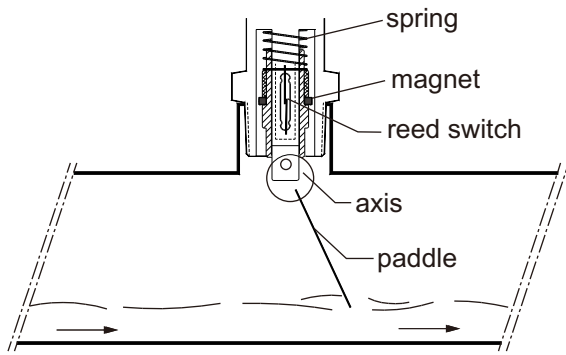

Switch on in case of liquid flowing in pipes

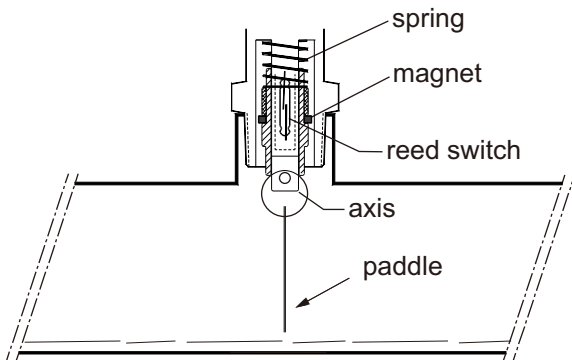

Switch off in case of no moving liquid in pipes

SECTIONAL DRAWINGS

1. O-Ring
2. Paddle
3. Axis
4. Reed switch
5. Spring
6. Magnet
7. Housing
8. Screw
9. Center rod

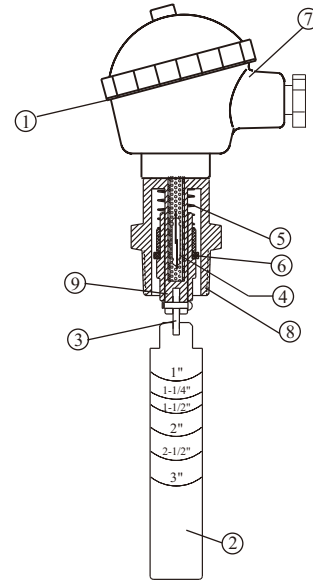

NEPSI

MODEL: SF1710

Explosion proof model

MODEL: SF1800

Standard model

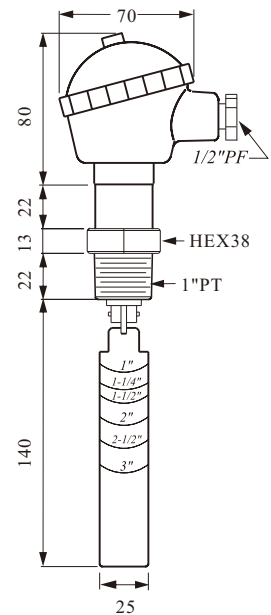
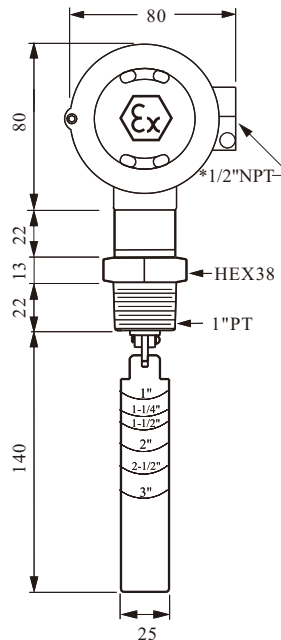

*Optional part



Spec.	Model	SF1710	SF1800
Housing material		Aluminum Alloy, Ex d IIC T6~T4	Aluminum Alloy, IP65
Operation temp.		-30°C~100°C	-30°C~150°C
Wetted material		SUS304	SUS304
Operation pressure		Max. 355 PSIG	Max. 355 PSIG
Pressure drop allowance		3 PSIG	3 PSIG
Set point tolerance		± 25%	± 25%
Repeatability tolerance		± 5%	± 5%
Contact capacity		60W 220Vac/200Vdc, SPDT	60W 220Vac/200Vdc, SPDT

FLOW CONTROL RANGE TABLE

Paddle Length	Flow Volume Gallon/Min.	1"		1-1/2"		2"		2-1/2"		3"	
		Act.	De-Act.	Act.	De-Act.	Act.	De-Act.	Act.	De-Act.	Act.	De-Act.
1"		4.7	3.9	10.9	8.3	19.9	16.1				
1-1/4"				7.7	6.1	16.5	12.3	31.3	22.8		
1-1/2"				5.7	4.5	13.4	9.5	25.2	18.5		
2"						8.4	6.3	15.1	12.8	29.7	21.9
2-1/2"								13.9	10	20.4	15.4
3"										17.1	12.8

※ 1 Gallon=3.7854 Litter

INSTALLATION

1. The paddle length is dependent on the lowest paddle point to actuate the switch. Cut the paddle at appropriate pipe size mark or wherever desired. The minimum is 1".
2. The paddle must be at a right angle to the direction of flow
3. The FLOW mark on the screw must be parallel to the pipe.
4. Before installing the unit to a tee pipe, apply thread seal tape to the screw and then tighten.

- Not recommended for 1" or smaller NPT plastic pipes.

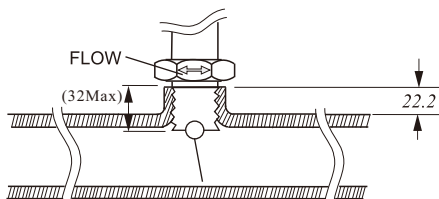

CAUTION

1. The pressure and temperature ranges as shown in the catalog, must not be exceeded and also take the abrupt pressure and temperature into considerations.
2. Large sudden changes in liquid temperature and density (specific gravity) changes will influence the flow switch accuracy
3. Although highly rigid and durable, shock and vibration should be minimized.
4. Excessive fluid debris might inhibit paddle operation. Occasionally remove switch and clean off any debris.
5. Sealing electrical connections and the connection will reduce moisture damage.